

# NAMUR Mounted, *Reflex* Solenoid Valve

RGS

## Description

Solenoid valve designed for direct mounting onto 1/4 turn pneumatically operated valve actuators meeting 'NAMUR' standard fixing dimensions. Value engineered for single-coil, safe area applications.

## Features

- Top face air connection.
- 1/4" BSP mains air connection and exhaust ports.
- Screwdriver override as standard.
- Integrated Exhaust to Spring (ETS) feature in 3/2 position.

## Conversion Facility

- Built in 3/2 to 5/2 function conversion facility for spring return and double acting actuators respectively. (see reverse)



## Product Code :

R 1 5 1 8 P K S 0

Voltage

See below for product code details

*Any of the below options that are not required enter '0' in relevant box.*

## Voltage

### Voltage:

24v DC

48v DC

24v AC (50/60 Hz)

110v AC (50/60 Hz)

240v AC (50/60 Hz)

### Code:

B

C

R

T

U

# NAMUR Mounted, *Reflex* Solenoid Valve

RGS

5/2 Function

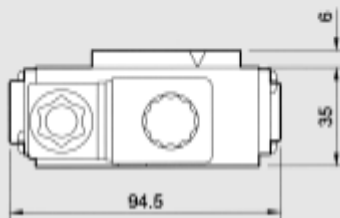
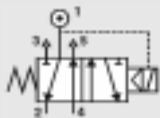

3/2 Function with E.T.S.

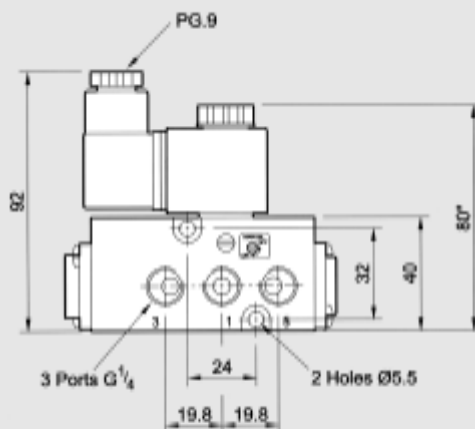

**Conversion Facility :**

Valve is fitted with a change over plate which allows the valve to be converted from 3/2 to 5/2 function quickly and easily.

In 3/2 function a proportion of clean air exhausting from the actuator is fed back into the spring chamber.

\* Minimum height with plug connector rotated through 90 degrees.

Material Specification	Standard
Body	Black Anodised Aluminium (Dural)
Spool	Hard Anodised Aluminium PTFE impregnated
Spacers	Glass filled Acetal
Seals	Nitrile
Spring	Stainless Steel
Mounting Screws	Stainless Steel
Change over plate and End Caps	Nylon 66 30% glass filled
Gasket	Nitrile

Valve Specification	Standard
Port Connection Size	1/4" NPT
Working Pressure	2 to 8 bar
Cv Factor	0.7
Flow Rate (at 6 bar with 1 bar pressure drop)	675 l/min
Maximum Ambient Temperature	+80 C
Minimum Working Temperature	-10 C

Coil Type	MC30 Plug & Socket
Area Class	Safe
Area Category	N/A
Ingress Protection	IP65
Cable Entry	PG.9
Ambient Temperature	-10 C to 80 C
Coil Class	Wire Class H, other parts Class F